

# SIEMENS



## RDF660T

**Flush-mounted room thermostat with weekly time program**

**Basic Documentation**

# Table of Contents

<b>1</b>	<b>About this document</b> .....	<b>5</b>
1.1	Revision history .....	5
1.2	Reference documents.....	5
1.3	Before you start .....	5
1.3.1	Copyright.....	5
1.3.2	Quality assurance .....	5
1.3.3	Document user/request to the reader .....	5
<b>2</b>	<b>Overview</b> .....	<b>7</b>
2.1	Types .....	7
2.2	Functions.....	7
2.3	Accessories .....	8
2.4	Equipment combinations.....	8
<b>3</b>	<b>Notes</b> .....	<b>10</b>
3.1	Mounting and installation .....	10
3.2	Commissioning.....	11
3.3	Operation .....	12
3.4	Disposal .....	14
3.5	Cyber security disclaimer .....	14
<b>4</b>	<b>Functions</b> .....	<b>15</b>
4.1	Temperature control .....	15
4.2	Operating modes .....	16
4.2.1	Different ways to influence the operating mode .....	17
4.3	Room temperature setpoint.....	19
4.3.1	Description.....	19
4.3.2	Setting and adjusting setpoints.....	20
4.4	Application overview .....	21
4.4.1	Applications for fan coil systems.....	22
4.4.2	Applications for universal systems.....	23
4.4.3	Application for heat pump systems .....	24
4.5	Additional functions.....	25
4.5.1	Sensors and changeover functions .....	26
4.5.2	Hotel keycard/Presence detector.....	27
4.5.3	Output functions.....	27
4.5.4	Monitoring and limitation functions .....	28
4.5.5	User operation / Indication .....	29
4.5.6	Prevention operation .....	29
4.6	Control sequences.....	30
4.6.1	Overview of sequences (setting via P01).....	30
4.6.2	2-pipe fan coil unit.....	31
4.6.3	2-pipe fan coil unit with electric heater .....	32
4.6.4	4-pipe fan coil unit.....	33
4.6.5	Chilled/heated ceiling and radiator applications .....	34
4.6.6	Compressor applications.....	34

4.6.7	Setpoints and sequences .....	35
4.7	Control outputs .....	36
4.7.1	Overview.....	36
4.8	Fan control .....	37
4.9	Multifunctional input, digital input.....	40
4.10	Auto Timer.....	42
4.11	Handling system faults .....	45
4.12	Infrared remote control.....	45
4.13	Control parameters .....	45
4.13.1	Parameter setting via local HMI .....	46
4.13.2	Service level parameters .....	47
4.13.3	Expert level parameters with diagnostics and test.....	48
<b>5</b>	<b>Connection.....</b>	<b>51</b>
5.1	Connection terminals .....	51
5.2	Connection diagrams .....	51
<b>6</b>	<b>Technical data.....</b>	<b>52</b>
<b>7</b>	<b>Dimensions .....</b>	<b>55</b>
<b>Index</b>	<b>.....</b>	<b>56</b>



# 1 About this document

## 1.1 Revision history

Edition	Date	Changes	Section
1	January 2021	First version.	All
1.1	March 2021	<ul style="list-style-type: none"> <li>Update Multifunctional input info</li> <li>Add setpoint related info</li> </ul>	4.9, 4.13.3 4.3.2
2	May 2021	<ul style="list-style-type: none"> <li>Update commissioning and display info</li> </ul>	3.2, 3.3
3	May 2021	<ul style="list-style-type: none"> <li>Add monitor input info</li> </ul>	2.2, 4.9, 4.13.3

## 1.2 Reference documents

Subject	Ref.	Document title	Document number
Flush-mounted room thermostat for Fan coils, with LCD, RDF660T	[1]	Mounting instructions and operating instructions	A6V12064527
	[2]	Data sheet	A6V12048672

## 1.3 Before you start

### 1.3.1 Copyright

This document may be duplicated and distributed only with the express permission of Siemens, and may be passed only to authorized persons or companies with the required technical knowledge.

### 1.3.2 Quality assurance

This document is prepared with great care.

- The contents of this document are checked at regular intervals.
- Any corrections necessary are included in subsequent versions.
- Documents are automatically amended as a consequence of modifications and corrections to the products described.

Please make sure that you are aware of the latest document revision date.

If you find lack of clarity while using this document, or if you have any criticisms or suggestions, please contact the Product Manager in your nearest branch office.

The addresses of the Siemens Regional Companies are available at [www.buildingtechnologies.siemens.com](http://www.buildingtechnologies.siemens.com).

### 1.3.3 Document user/request to the reader

Before using products from Siemens Industry, Inc., it is important that you read the documents supplied with or ordered at the same time as the products (equipment, applications, tools, and so on) carefully and in full.

We assume that persons using our products and documents are authorized and trained appropriately and have the technical knowledge required to use our products as intended.

More information on the products and applications is available:

- On the intranet (Siemens employees only) at <https://wse04.siemens.com/content/P0002723/SitePages/Home.aspx>
- From the Siemens branch office near you [www.buildingtechnologies.siemens.com](http://www.buildingtechnologies.siemens.com) or from your system supplier
- From the support team at headquarters [fieldsupport-zug.ch.sbt@siemens.com](mailto:fieldsupport-zug.ch.sbt@siemens.com) if there is no local point of contact

Siemens assumes no liability to the extent allowed under the law for any losses resulting from a failure to comply with the aforementioned points or for the improper compliance of the same.

## 2 Overview

### 2.1 Types

Product no.	Stock no.	Operating voltage	Control outputs			Fan types		Time program	Backlit LCD	Infrared receiver <sup>1)</sup>	Suitable conduit box	Color
			On/Off	3-pos	DC 0...10 V	3-speed	DC 0...10 V					
RDF660T	S55770-T434	AC 230 V	✓	✓	-	-	✓	✓	✓	✓	Square or round	White

<sup>1)</sup>Order infrared remote control separately

### 2.2 Functions

#### Use

#### Applications

Room temperature control in individual rooms and zones:

- Heated or cooled with 2-pipe fan coil units
- Heated or cooled with 2-pipe fan coil units with electrical heater
- Heated and cooled with 4-pipe fan coil units

The room thermostat controls:

- One ECM fan
- One or two on/off valve actuators
- One on/off valve actuator and one 1-stage electric heater
- One 3-position valve actuator
- One 1-stage compressor with electric heater

Used in systems with:



- Heating or cooling
- Automatic heating/cooling changeover
- Manual heating/cooling changeover
- Heating and cooling (e.g. 4-pipe system)

#### Functions

- Maintain room temperature via built-in temperature sensor or external room temperature/return air temperature sensor
- Automatic or manual changeover between heating and cooling
- Select application via DIP switches
- Select operating mode via operating mode button on the thermostat
- ECM fan control (automatic or manual)
- Display current room temperature or setpoint in °C and/or °F
- Minimum and maximum setpoint limitation
- Key lock (automatic and manual)
- 2 multifunctional inputs, freely selectable for:
  - External room temperature sensor or return air temperature sensor (AI)
  - Automatic heating/cooling changeover sensor (AI)
  - Window contact (DI)
  - Dew point sensor (DI)
  - Electrical heater enabled (DI)
  - Fault input (DI)
  - Monitor input (DI)





- Monitor input (AI)
- Automatic heating/cooling changeover sensor (DI)
- Presence detector (DI)
- Hotel keycard (DI)
- Advanced fan control function, i.e. fan kick, fan start, selectable fan operation (enable, disable or depending on heating or cooling)
- Purge function together with 2-port valve in a 2-pipe changeover system
- Reminder to clean filters
- Floor heating temperature limit
- User and parameter settings can be retained in case of power failure and operating mode can be returned to the previous operating mode, Comfort or Protection (depends on P27)
- Reload factory settings for commissioning and control parameters
- 7-day time program (can be disabled via P77): 8 programmable timers to switch over between Comfort and Economy
- Infrared remote control

## 2.3 Accessories

Description		SSN	Data sheet
Changeover mounting kit (50 pcs / package)		ARG86.3	N3009
Plastic mounting spacer for flush-mounted thermostats to increase the headroom in the conduit box by 10 mm		ARG70.3	N3009





Note: Order accessories separately.

## 2.4 Equipment combinations







Type of unit		Product no.	Data sheet <sup>1)</sup>
Cable temperature or changeover sensor, cable length 2.5 m NTC (3 kΩ at 25 °C)		QAH11.1	1840
Room temperature sensor NTC (3 kΩ at 25 °C)		QAA32	1747
Cable temperature sensor cable length 4 m NTC (3 kΩ at 25 °C)		QAP1030/UFH	1854
Condensation monitor		QXA21..	A6V10741072



### On/Off actuators

Type of unit		Product no.	Data sheet <sup>*)</sup>
Electromotive On/Off actuator		SFA21..	4863
Electromotive On/Off valve and actuator (only available in AP, UAE, SA and IN)		MVI../MXI..	A6V11251892
Zone valve actuator (only available in AP, UAE, SA and IN)		SUA..	4832
Thermal actuator (for radiator valves)		STA23...	4884
Thermal actuator (for small valves 2.5 mm)		STP23...	4884

### 3-position actuators

Type of unit		Product no.	Data sheet <sup>*)</sup>
Electric actuator, 3-position (for radiator valves)		SSA31..	4893
Electric actuator, 3-position (for 2- and 3-port valves/V..P45)		SSC31	4895
Electric actuator, 3-position (for small valves 2.5 mm)		SSP31..	4864
Electric actuator, 3-position (for small valves 5.5 mm)		SSB31..	4891
Electric actuator, 3-position (for small valve 5 mm)		SSD31..	4861
Electric actuator, 3-position (for valves 5.5 mm)		SAS31..	4581

<sup>\*)</sup> The documents can be downloaded from <http://siemens.com/bt/download>.

## 3 Notes

### 3.1 Mounting and installation

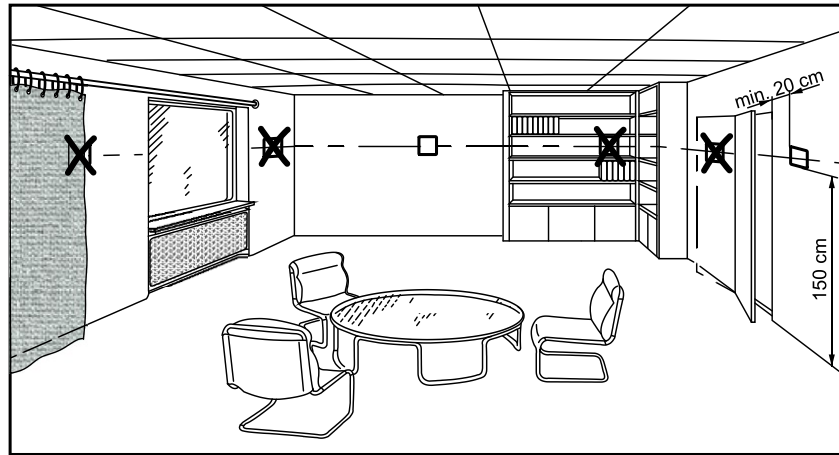

#### Mounting

- Mount the room thermostat on the conduit box.
- Do not mount on a wall in niches or bookshelves, behind curtains, above or near heat sources, or exposed to direct solar radiation.
- Mount about 1.5 m above the floor.
- Mount the room thermostat in a clean, dry indoor place without direct airflow from a heating / cooling device, and not exposed to dripping or splash water.
- Before removing the front cover, disconnect the power supply.

#### Wiring

- See Mounting Instructions A6V12064527 enclosed with the thermostat.
- ⚠ Wire, protect and earth in compliance with local regulations.
- Adapt the line diameters to the rated value of the installed overcurrent protection device as per local regulations.
- ⚠ Use only valve actuators rated for AC 230 V.
- ⚠ The AC 230 V mains supply line must have an external circuit breaker with a rated current of no more than 10 A.
- ⚠ Isolate the cables of SELV inputs X1-M/X2-M, if the conduit box carries AC 230 V mains voltage.
- ⚠ Inputs X1-M or X2-M of different units (e.g. summer/winter switch) may be connected in parallel with an external switch. Consider overall maximum contact sensing current for switch rating.
- No metal conduits
- No cables provided with metal sheathing.
- ⚠ Disconnect the thermostat from power supply before removing from the mounting plate.
- ⚠ The device does not support hot-plug.

## 3.2 Commissioning

Set the thermostat application via the DIP switches before snapping the front panel onto the mounting base.

After power is applied, the thermostat resets all LCD segments light up indicating that resetting was correct. After reset, which takes about 3 seconds, the thermostat is ready for commissioning by qualified HVAC staff.

The control parameters of the thermostat can be set to ensure optimum performance of the entire system (see basic documentation A6V12166490).

### Note

After power failure, the thermostat restarts in the same mode as before, Comfort or Protection (depends on P27).

### Control sequence

The control sequence may need to be set via parameter P01 depending on the application. The factory setting for the 2-pipe application is “Cooling only”; and “Heating and cooling” for the 4-pipe application.

### Compressor-based application

When the thermostat is used with a compressor, adjust the minimum output On-time (P48) and Off-time (P49) for Y1/Y2 to avoid damaging the compressor or shortening its life due to frequent switching.

### Calibrate sensor

Recalibrate the temperature sensor if the room temperature displayed on the thermostat does not match the room temperature measured (after minimum 1 hour of operation). To do this, change P05.

### Setpoint and range limitation

We recommend reviewing the setpoints and setpoint ranges (P08...P12) and changing them as needed to achieve maximum comfort and save energy.

### 3.3 Operation

The thermostats consist of 2 parts:

- Front panel with electronics, operating elements and built-in room temperature sensor.
- Mounting base with power electronics.

The rear of the mounting base contains the screw terminals.

Slide the front panel in the mounting base and snap on.

#### Operation and settings

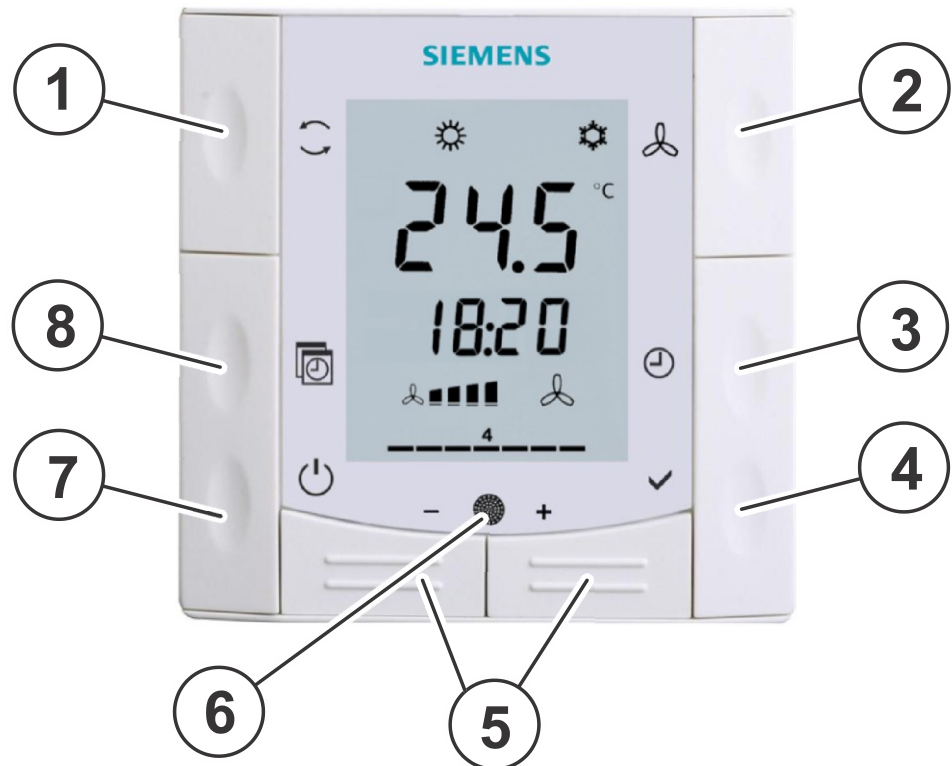

1. Change operating mode selector
2. Change fan operation
3. Set time of day and weekday
4. Confirm
5. Adjust setpoint, control parameters and time of day
6. Infrared receiver
7. Protection
8. Auto timer program

Display

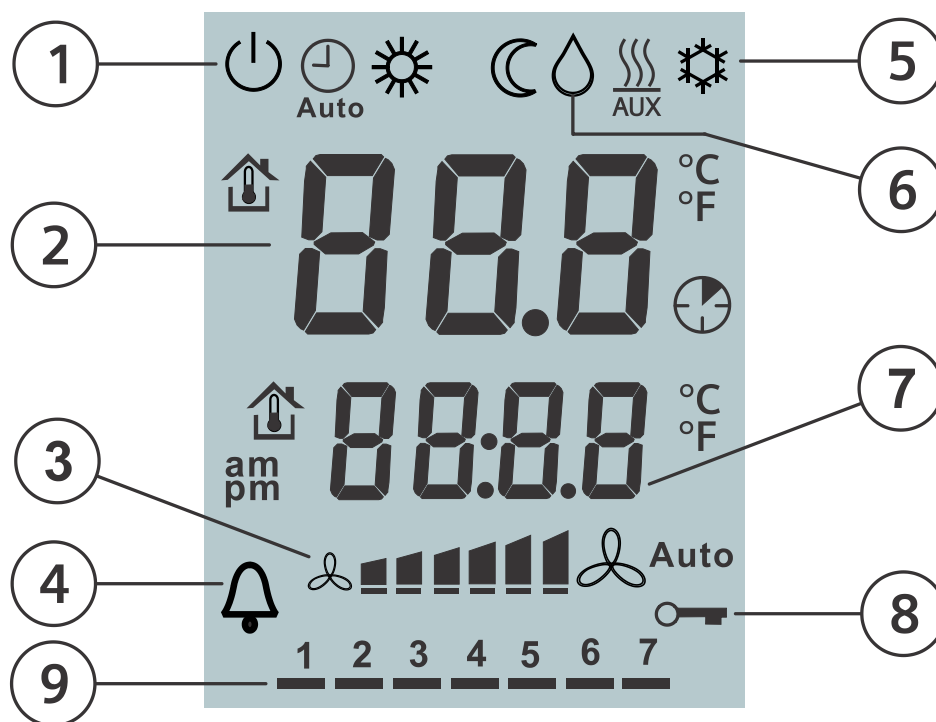

1. Operating mode
  - Protection
  - Auto timer mode
  - Comfort
  - Economy
2. Display room temperature, setpoints and control parameters.
  - Symbol to display the current room temperature
3. Fan mode
  - Auto Auto fan active
  - Fan speed low, medium, high
4. Indicate fault or reminder
5. Heating/cooling mode
  - Cooling
  - Heating
  - Electrical heater active
6. Condensation in room (dewpoint sensor active)
7. Room temperature, setpoint or current time of day
8. Key lock active
9. Weekday 1...7 (1 = Monday/7 = Sunday)

## 3.4 Disposal

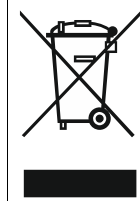

The device is considered an electronic device for disposal in accordance with the European Guidelines and may not be disposed of as domestic garbage.

- Dispose of the device through channels provided for this purpose.
- Comply with all local and currently applicable laws and regulations.

## 3.5 Cyber security disclaimer

Siemens provides a portfolio of products, solutions, systems and services that includes security functions that support the secure operation of plants, systems, machines and networks. In the field of Building Technologies, this includes building automation and control, fire safety, security management as well as physical security systems. In order to protect plants, systems, machines and networks against cyber threats, it is necessary to implement – and continuously maintain – a holistic, state-of-the-art security concept. Siemens' portfolio only forms one element of such a concept.

You are responsible for preventing unauthorized access to your plants, systems, machines and networks which should only be connected to an enterprise network or the internet if and to the extent such a connection is necessary and only when appropriate security measures (e.g. firewalls and/or network segmentation) are in place. Additionally, Siemens' guidance on appropriate security measures should be taken into account. For additional information, please contact your Siemens sales representative or visit <https://www.siemens.com/global/en/home/company/topic-areas/future-of-manufacturing/industrial-security.html>.

Siemens' portfolio undergoes continuous development to make it more secure. Siemens strongly recommends that updates are applied as soon as they are available and that the latest versions are used. Use of versions that are no longer supported, and failure to apply the latest updates may increase your exposure to cyber threats. Siemens strongly recommends to comply with security advisories on the latest security threats, patches and other related measures, published, among others, under <https://www.siemens.com/cert/en/cert-security-advisories.htm>.

## 4 Functions

### 4.1 Temperature control

**General note:  
Parameters**

Setting control parameters (P01, etc. mentioned throughout the document), see Control parameters [→ 45].

**Temperature control**

The thermostat acquires the room temperature via built-in sensor, external room temperature sensor (QAA32), external return air temperature sensor (QAH11.1/QAP1030/UFH), and maintains the setpoint by delivering actuator control commands to heating equipment, cooling equipment, or both. The following control outputs are available:

- On/Off control (2-position)
- Modulating PI/P control with 3-position control output (only for 2-pipe applications)





The switching differential or proportional band is 2 K for heating mode and 1 K for cooling mode (adjustable via P30 and P31).

The integral action time for modulating PI control is 45 minutes (adjustable via P35).

**Display**

The display shows the acquired room temperature or the Comfort setpoint, selectable via P06. The factory setting displays the current room temperature. Use P04 to display the room temperature or setpoint in °F rather than °C as needed.



- With automatic changeover or continuous heating/cooling, symbols  /  indicate that the system currently heats or cools (heating or cooling output is activated).
- With manual changeover (P01 = 2), symbols  /  indicate that the system currently is in heating or cooling mode. Thus, the symbols are displayed even when the thermostat is in the neutral zone.





**Concurrent display of °C and °F**

Concurrent display of the current temperature or setpoint in °C and °F is available (P07 = 1) on the thermostat without weekly time program.

## 4.2 Operating modes

The thermostat operating mode can be influenced in different ways (see Different ways to influence the operating mode [→ 17]). Specific heating and cooling setpoints are assigned to each operating mode.

The following operating modes are available:

Operating mode	Icon	Description
Auto Timer		<p>In Auto Timer mode, the thermostat automatically changes from Comfort to Economy as per 8 preprogrammed timers. Auto Timer mode symbol  along with related operation mode symbol (Comfort or Economy) displays on the screen.</p> <p>The thermostat automatically selects the fan speed based on setpoint and actual room temperature. And automatic fan is the default fan speed in Auto Timer mode.</p>
Comfort		<p>In Comfort, the thermostat maintains the Comfort setpoint. This setpoint can be defined via P08, P09 and P10.</p> <p>Also, it can be adjusted via the +/- buttons.</p> <p>The fan can be set to automatic or manual fan speed: Low, medium or high.</p> <p>The thermostat switches to Comfort when:</p> <ul style="list-style-type: none"> <li>• The presence detector is active (room is occupied) <sup>*)</sup></li> </ul>
Economy		<p>A preset setpoint in Economy can be defined via P11 and P12.</p> <p>The thermostat switches to Economy when:</p> <ul style="list-style-type: none"> <li>• The operating mode button is pressed (only possible if P02 is set to 2 or 4),</li> <li>• Hotel keycard is removed or presence detector is inactive. The contact can be connected to multifunctional input X1 or X2. Set P38 or P40 to 10 or 11 (P02 is irrelevant) <sup>*)</sup></li> </ul>
Protection		<p>In Protection, the system is:</p> <ul style="list-style-type: none"> <li>• Protected against frost (factory setting: 8 °C, configurable via P65)</li> <li>• Protected against overheating (factory setting: OFF, configurable via P66)</li> </ul> <p>The thermostat switches to Protection when:</p> <ul style="list-style-type: none"> <li>• The operating mode button is pressed</li> <li>• The window contact is active (open window)</li> </ul>

### Note

<sup>\*)</sup> Hotel keycard, presence detector or window contact: Use only one input source, either input X1 or X2. User operations are ineffective if hotel keycard is removed, presence detector is inactive or window contact is active (window is open).



## 4.2.1 Different ways to influence the operating mode























### Priority of operating mode interventions

Different interventions can influence the operating mode.  
The following table shows the priorities of different interventions.  
A lower number means higher priority.

Priority	Description	Remark
①	Commissioning	In the parameter setting mode, you can always command an operating mode independent of all other settings or intervention local input.
②	Window contact	If the contact is closed, the operating mode changes to Protection. This overrides the operating mode on the thermostat.
	<b>Note:</b> Only one input source must be used, either local input X1 or X2.	
③	Auto timer	When the time program mode is selected, the operating mode is switched according to the set time and day.
③	Presence detector	If a room is occupied, the operating mode changes to Comfort. This overrides the operating mode on the thermostat. Unoccupied rooms set back the thermostat to the previous operating mode.
③	Operating mode button	Users can change the operating mode via the operating mode button.
③	Hotel keycard	If keycard is removed or room is unoccupied, the operating mode changes to Economy with HMI locked. When hotel keycard is active, the thermostat returns to the previous operating mode.
③	Temporary extended Comfort via operating mode button	The operating mode can be temporarily changed from Economy to Comfort by pressing the operating mode button, if an extended Comfort period > 0 (P68)
	<b>Note:</b> Higher priority commands override lower priority commands.	

**Availability of Economy mode**

The operating mode is selected locally via the operating mode button. The behavior of the operating mode button (user profile) can be defined via P02, factory setting is P02 = 3.

P02	Without time schedule	With time schedule	Description
1	 ⇒ 	 AUTO ⇒  ⇒ 	<ul style="list-style-type: none"> <li>Switching manually between 2 modes, Economy is not available (factory setting)</li> <li>Suited for commercial buildings</li> <li>If a time schedule is available, then Comfort can be temporarily extended (see Different ways to influence the operating mode [→ 18])</li> </ul>
2	 ⇒  ⇒ 	 AUTO ⇒  ⇒  ⇒ 	<ul style="list-style-type: none"> <li>Switching manually between 3 modes</li> <li>Suited for homes and rooms where manual switching to Economy is desired</li> <li>If a time schedule is available, then the Comfort can be temporarily extended (see Different ways to influence the operating mode [→ 18])</li> </ul>
3	 ⇒ 	 ⇒ 	<ul style="list-style-type: none"> <li>Switching manually between 2 modes, Economy is not available (factory setting)</li> <li>Suited for hotel guest rooms or commercial buildings</li> </ul>
4	 ⇒  ⇒ 	 ⇒  ⇒ 	<ul style="list-style-type: none"> <li>Switching manually between 3 modes</li> <li>Suited for homes and rooms where manual switching to Economy is desired</li> </ul>

**Window contact**

The thermostat is forced into Protection when the window is open. The contact can be connected to multifunctional input X1 or X2. Set P38 or P40 to 3. User operations are ineffective when window contact is active.

**Note**

Only one input source must be used, either local input X1 or X2.

**Presence detector**

The operating mode can be changed to Comfort or Economy based on room occupancy (room occupied or unoccupied, via presence detector or keycard). For details, see Hotel keycard/Presence detector [→ 27]

**Temporary timer to extend Comfort mode**

Comfort mode can be temporarily extended (e.g., working after business hours or on weekends) when the thermostat is in Economy.

1. Press the operating mode button to return to Comfort for the preset period (P68).
2. Press the operating mode button again to stop the schedule.

The following conditions must be fulfilled:

- Mode selection via operating mode button is set to "Auto-Comfort-Protection" (P02 = 1) or "Auto-Comfort-Economy-Protection" (P02 = 2)
- P68 (extend Comfort period) is greater than 0

During the temporary Comfort extension, symbol ☺ is displayed.

When P68 (extend Comfort period) equals 0, extended Comfort cannot be activated; pressing the left button switches the thermostat to Protection.

## 4.3 Room temperature setpoint

### 4.3.1 Description

**Comfort mode**



The factory setting for the Comfort basic setpoint is 21 °C and can be changed in the thermostat's EEPROM via P08.

The Comfort setpoint can be adjusted via the +/- buttons.

**Temporary setpoint**

When "Temporary comfort setpoint" is enabled via P69, the Comfort setpoint adjusted via the + / - buttons is set back to the Comfort basic setpoint stored in P08 only when the operating mode is changed.

**Setpoint limitation**

For energy saving purposes, the setpoint setting range can be limited to minimum (P09) and maximum (P10).

**P09 < P10**

- If the minimum limit P09 is set lower than the maximum limit P10, both heating and cooling can be adjusted between these 2 limits.

**P09 ≥ P10**

- For heating or cooling applications (e.g. 2-stage):
  - The setting range in cooling mode is P09...35 °C in place of 5...35 °C
  - The setting range in heating mode is 5...P10 °C in place of 5...35 °C
- For heating and cooling applications (e.g. 4-pipe):
  - The cooling and heating setpoint can be adjusted
  - The setting range in cooling mode is P09...35 °C in place of 5...35 °C
  - The setting range in heating mode is 5...P10 °C in place of 5...35 °C

Example	2-pipe heating OR cooling	4-pipe heating AND cooling
P09 < P10	<p>5°C      18°C      25°C      35°C</p> <p>          P09      P10</p> <p style="text-align: right;"><small>A6V12114068Z05</small></p> <p>Cooling setpoint adjustable: 18...25 °C Heating setpoint adjustable: 18...25 °C</p>	<p>5°C      18°C      25°C      35°C</p> <p>          P09      P10</p> <p style="text-align: right;"><small>A6V12114068Z05</small></p> <p>Cooling setpoint adjustable: 18...25 °C Heating setpoint adjustable: 18...25 °C</p>
P09 ≥ P10	<p>5°C      21°C      25°C      35°C</p> <p>          P10      P09</p> <p style="text-align: right;"><small>A6V12114068Z06</small></p> <p>Cooling setpoint adjustable: 25...35 °C Heating setpoint adjustable: 5...21 °C</p>	

**Economy mode**



Use control parameters P11 and P12 to adjust Economy setpoints.

The heating setpoint is 15 °C (factory setting), the cooling setpoint is 30 °C.

**Protection mode**



Use P65 and P66 to adjust the Protection setpoints.

The heating setpoint is 8 °C (frost protection, factory setting) and OFF for cooling.



### CAUTION

If a setpoint (Economy or Protection) is set to OFF, the thermostat does not control the room temperature in the corresponding operating mode (heating or cooling). As a result, there is no protective heating or cooling function and thus risk of frost during heating or risk of overtemperature during cooling!

The Economy setpoints (P11, P12) can be accessed at the Service level;  
Protection setpoints (P65, P66) at the Expert level.

## 4.3.2 Setting and adjusting setpoints

Room temperature setpoints can be:

- Set during commissioning
- Adjusted during runtime

### Room temperature: Comfort setpoint

The source can be following:

- Local HMI

The thermostat saves the setpoints to

- EEPROM in the form of parameters

The figure below shows the interrelation:

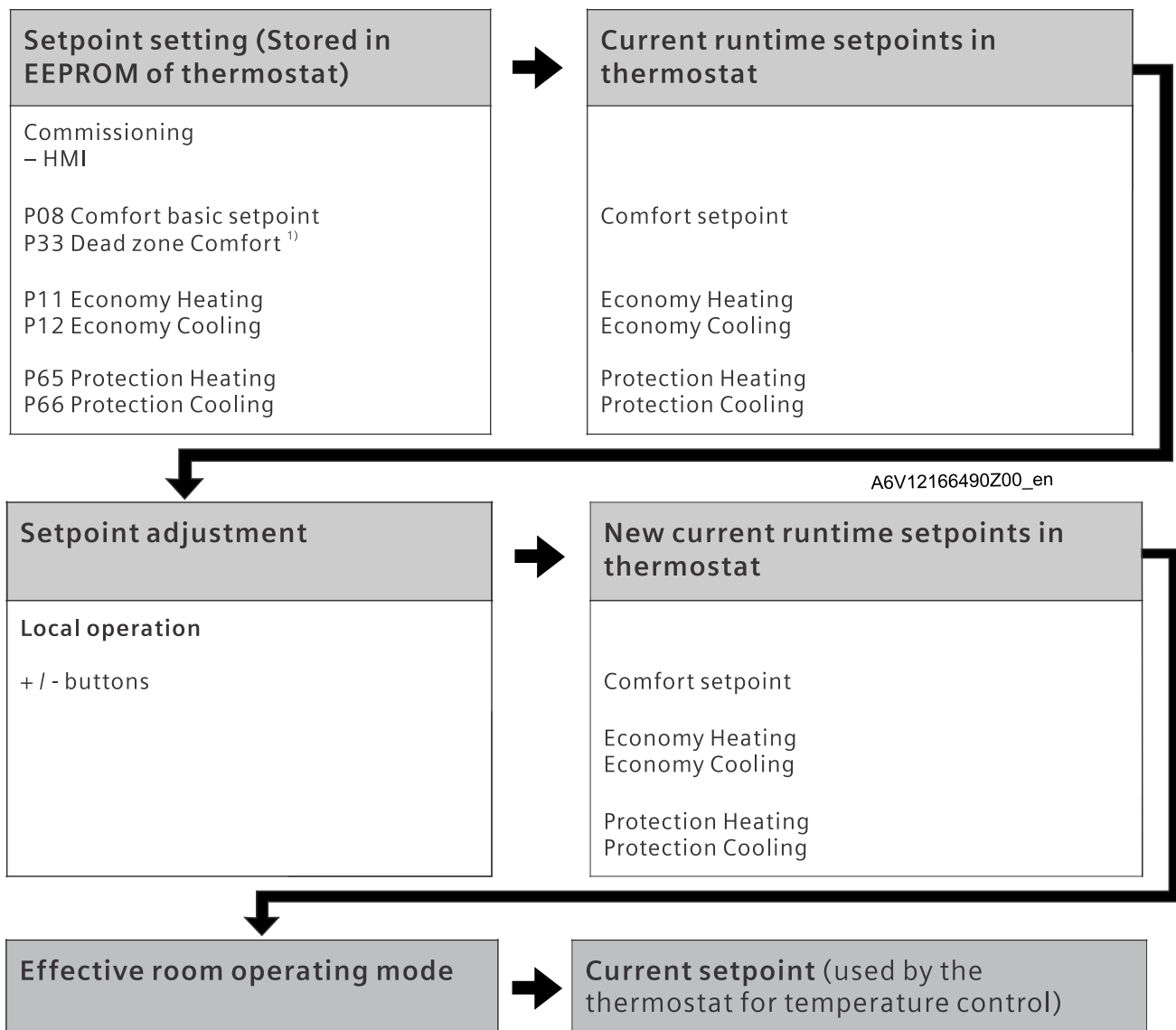

<sup>1)</sup> Only required for heating and cooling applications (see Setpoints and sequences [→ 35])

**General notes:**

- Setting the Comfort basic setpoint resets the runtime Comfort setpoint to the basic setpoint.

**Notes on setpoint adjustment**

- The resulting (current) setpoint for heating and cooling is limited by the Protection setpoint; if the Protection setpoint is OFF, then minimum 5 °C and maximum 40 °C are used.
- The resulting setpoints for cooling and heating of the same operating mode are min. 0.5 K apart.

## 4.4 Application overview

The thermostats support the following applications, which can be configured using the DIP switches on the front panel of the unit. Depending on the type, On/Off or modulating control outputs are available.

### 4.4.1 Applications for fan coil systems

Application and output signal, DIP switches, diagram			
<p><b>2-pipe fan coil unit</b> On/Off (heating or cooling)</p>		<p><b>2-pipe fan coil unit with electric heater</b> (heating or cooling) On/Off</p>	
<p><b>2-pipe fan coil unit</b> modulating, 3-position (heating or cooling)</p>		<p><b>4-pipe fan coil unit</b> On/Off (heating and cooling)</p>	

- V1 Heating or heating/cooling valve actuator
- V2 Cooling valve actuator
- E1 Electric heater

- B1 Return air temperature sensor or external room temperature sensor (optional)
- B2 Changeover sensor (optional)
- M1 ECM fan

### 4.4.2 Applications for universal systems

Application and output signal, DIP switches, diagram			
<p><b>Chilled/heated ceiling</b> On/Off (heating or cooling)</p>		<p><b>Chilled/heated ceiling with electric heater</b> On/Off (heating or cooling)</p>	
<p>3191S11</p>		<p>3191S12</p>	
<p><b>Chilled/heated ceiling modulating, 3-position</b> (heating or cooling)</p>		<p><b>Chilled ceiling and radiator</b> On/Off (heating and cooling)</p>	
<p>3191S11</p>		<p>3191S13</p>	

V1 Heating or heating/cooling valve actuator

V2 Cooling valve actuator

E1 Electric heater

B1 Return air temperature sensor or external room temperature sensor (optional)

B2 Changeover sensor (optional)

D3 Dewpoint sensor

### 4.4.3 Application for heat pump systems

#### Application and output signal, DIP switches, diagram

**1-stage compressor** On/Off  
(heating or cooling)

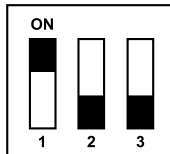

**1-stage compressor with electric heater**  
(heating or cooling) On/Off

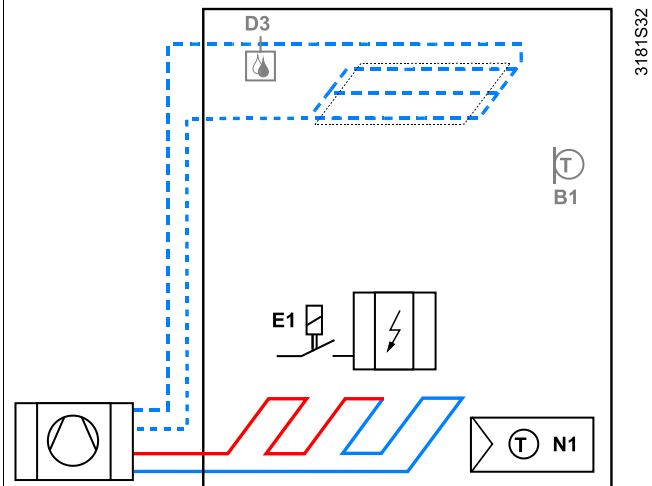
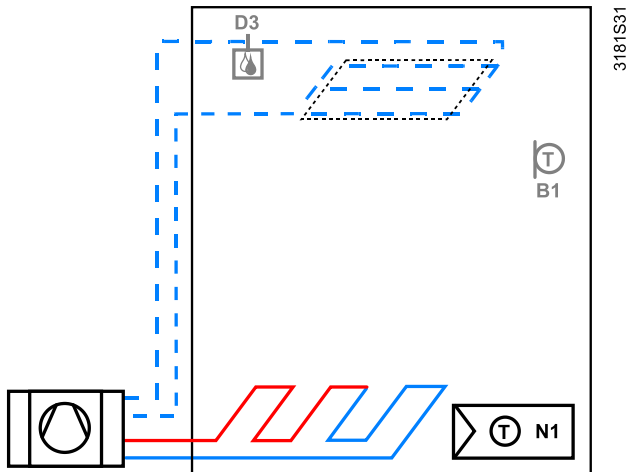
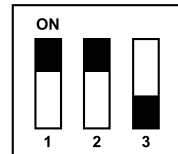

**1-stage compressor** On/Off  
(heating and cooling)

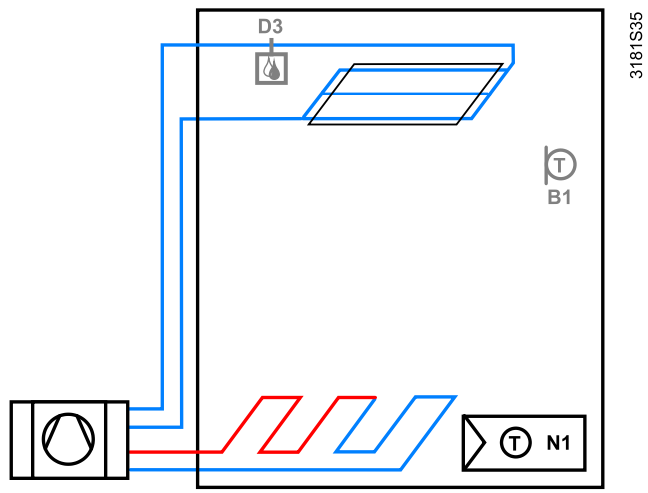
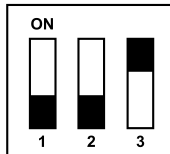

N1 Thermostat  
Terminal Y1: Heating (H&C) or Heating/Cooling  
Terminal Y2: Cooling (H&C)

E1 Electric heaters

B1 Return air temperature sensor or external room  
temperature sensor (optional)

D3 Dewpoint sensor



## 4.5 Additional functions

Functions (parameters)	Description	RDF660T
<b>Sensors and changeover functions [→ 26]</b>		
<ul style="list-style-type: none"> <li>Automatic heating/cooling changeover via changeover sensor (P36, P37)</li> <li>Changeover switch (P38, P40)</li> </ul>	Thermostat runs sequences depending on water temperature	✓
<ul style="list-style-type: none"> <li>Manual heating/cooling changeover (P01)</li> </ul>	Heating / cooling controlled manually by user (via HMI)	✓
<ul style="list-style-type: none"> <li>External/return air temperature sensor (P38, P40)</li> </ul>	Temperature measurement with external sensors	✓
<b>Hotel keycard/Presence detector [→ 27]</b>		
<ul style="list-style-type: none"> <li>Presence detector (P38, P40)</li> </ul>	Switch operating mode	✓
<b>Output functions [→ 27]</b>		
<ul style="list-style-type: none"> <li>Purge function (P50)</li> </ul>	To ensure correct acquisition of the water temperature	✓
<ul style="list-style-type: none"> <li>Minimum output On/Off time (P48, P49)</li> </ul>	To protect HVAC equipment, e.g., the compressor, and to reduce wear and tear	✓
<ul style="list-style-type: none"> <li>Floor heating</li> </ul>	Application without fan control	✓
<b>Monitoring and limitation functions [→ 28]</b>		
<ul style="list-style-type: none"> <li>Floor temperature limitation function (P51)</li> </ul>	For user Comfort and protect the floor	✓
<ul style="list-style-type: none"> <li>Dewpoint monitoring</li> </ul>	To prevent condensation damages to the building	✓
<b>User operation / Indication [→ 29]</b>		
<ul style="list-style-type: none"> <li>Key lock (P14)</li> </ul>	To limit access of unauthorized persons	✓
<b>Prevention operation [→ 29]</b>		
<ul style="list-style-type: none"> <li>Avoid damage from moisture (P61)</li> </ul>	To prevent moisture damage	✓

### 4.5.1 Sensors and changeover functions

#### Automatic heating/cooling changeover via changeover sensor (P36, P37)

If a cable temperature sensor (QAH11.1 + ARG86.3) is connected to X1, and P38 is set to 2, the water temperature acquired by the changeover sensor is used to change over from heating to cooling, or vice versa.

- When the **water temperature** is above 28 °C (adjustable via P37), the thermostat changes over to **heating** and remains there until the temperature drops below 16 °C (adjustable via P36).
- When the **water temperature** is below 16 °C (P36), the thermostat changes over to **cooling** and remains there until the temperature exceeds 28 °C (P37).
- If the water temperature is between the 2 changeover points immediately after power-up (within hysteresis), the thermostat starts in the previous mode.

The water temperature is acquired at 30 s intervals and the operating state is updated accordingly.

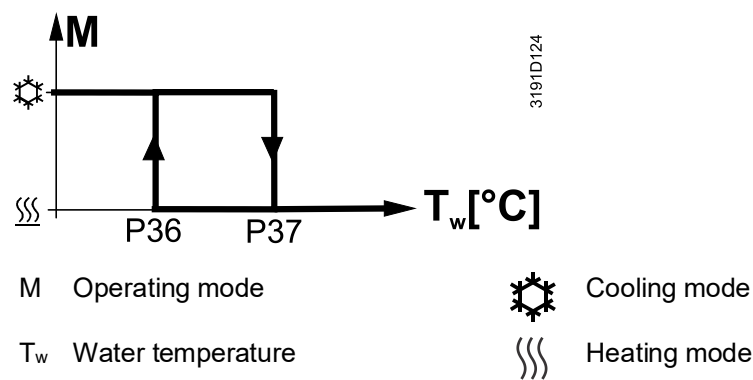

#### Note

The setting range is 10...25 °C for P36 and 27... 40 °C for P37.

#### Changeover switch (P38, P40)

The QAH11.1 cable temperature sensor for automatic heating / cooling changeover can be replaced by an external switch for manual, remote changeover:

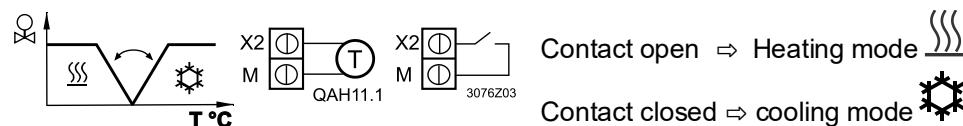

The sensor or switch connects to input terminal X1 or X2, depending on input commissioning (P38, P40).

See also Multifunctional input, digital input [→ 40].

#### Manual heating/cooling changeover (P01)

- An external switch is connected to X1/X2 (P38/P40 = 9) to change heating/cooling mode remotely.
- Manual heating/cooling changeover means selection via changeover button on the thermostat by repeatedly pushing the button until the required mode is displayed (automatic changeover via external sensor / switch connected to X1 or x2).
- If manual heating/cooling changeover is commissioned (P01 = 2), heating/cooling mode cannot be changed via changeover sensor/switch; it remains in the last mode selected locally via button.

#### External/return air temperature sensor (P38, P40)

The thermostat acquires the room temperature via built-in sensor, external room temperature sensor (QAA32), or external return air temperature sensor (QAH11.1 or QAP1030/UFH) connected to multifunctional input X1 or X2.

Inputs X1 and X2 must be commissioned accordingly. See Multifunctional input, digital input [→ 40].

### 4.5.2 Hotel keycard/Presence detector

The operating mode can be changed to Comfort or Economy based on room occupancy (room occupied or unoccupied, via presence detector or hotel keycard).

The presence detector or hotel keycard input switches the operating mode to Comfort when the room is occupied and switches back to the previous operating mode when the room is unoccupied.

The operating mode changes as per time schedule only when presence detector is active:

Time schedule	Presence detector behavior
Comfort mode	When the presence detector is activated or deactivated, the operating mode remains in Comfort.
Economy mode	<ul style="list-style-type: none"> <li>When the presence detector is activated, the operating mode changes to Comfort.</li> <li>When the presence detector is deactivated, the operating mode changes to Economy (Auto).</li> </ul>
Protection mode	Presence detection has no influence on the operating mode.
Not available	<ul style="list-style-type: none"> <li>When the presence detector is activated, the operating mode changes to Comfort.</li> <li>When the presence detector is deactivated, the operating mode changes to previous operating mode.</li> </ul>

### 4.5.3 Output functions

#### Purge function (P50)

The changeover sensor ensures changeover between heating and cooling based on the acquired water temperature. We recommend activating the Purge function (P50) with 2-port valves. This function ensures correct acquisition of the medium temperature even if the 2-port valve is closed for an extended period of time. The valve is opened for 1 to 5 minutes (adjustable) at 2-hour intervals during off hours. The function is valid for outputs On/Off and all applications.

**⚠ CAUTION! The Purge function (P50) must be disabled if the thermostat is used in compressor-based applications.**

#### Minimum output On/Off time (P48, P49)

Limit the On/Off switching cycle to protect HVAC equipment, e.g., the compressor, and to reduce wear and tear. The minimum output on time and off time for the 2-position control output can be adjusted from 1 to 20 minutes via P48 and P49. The factory setting is 1 minute.

Readjusting the setpoint or heating/cooling mode changeover immediately results in output state calculation; the outputs may not hold the minimum 1-minute On/Off time.

If P48 or P49 is set to greater than 1 minute, the minimum On/Off time for the control output is maintained as set, even if the setpoint or changeover mode is readjusted.

#### Floor heating/Floor cooling (P52)

All heating sequences can also be used for underfloor heating.

You can use fan coil unit heating/cooling sequences for underfloor heating or cooling by disabling the fan via P52.

### 4.5.4 Monitoring and limitation functions

#### Floor temperature limitation function (P51)

The floor temperature should be limited for two reasons: Comfort and protection of the floor.

The floor temperature sensor, connected to multifunctional input X1 or X2, acquires the floor temperature. If the temperature exceeds the parameterized limit (P51), the heating valve is fully closed until the floor temperature drops below the parameterized limit. This function is factory-set to Off (disabled).

Input X1 or X2 must be commissioned accordingly (P38/P40 = 1).

See Multifunctional input, digital input [→ 40].

#### Recommended values for P51

- Living rooms:  
Up to 26 °C for extended presence, up to 28 °C for short presence.
- Bathrooms:  
Up to 28 °C for extended presence, up to 30 °C for short presence.

The table below shows the relationship between parameter, temperature source and temperature display.

Parameter P51	External temp. sensor available	Source for display of room temperature	Output control according to	Floor temp. limitation function
OFF	No	Built-in sensor	Built-in sensor	Not active
OFF	Yes	External temp. sensor	External temp. sensor	Not active
10...50 °C	No	Built-in sensor	Built-in sensor	Not active
10...50 °C	Yes	Built-in sensor	Built-in sensor + limit by external sensor	Active

The "Floor temperature limitation" function influences the outputs listed in the table below:

Application	Output Y1	Output Y2	"Floor temp. limit" function impacts:			Remark
			Heating (P01 = 0/2/3)	Cooling P01 = 1/2/3	Heating and Cooling (P01 = 4)	
2-pipe	H/C valve		Y1	N/A		
2-pipe with electric heater	H/C valve	Electric heater	Y2	Y2 *)		Only electric heater
4-pipe	Heating valve	Cooling valve	Y1	N/A	Y1	

\*) If P13 = ON, electric heater is in cooling mode.

#### Note

Either a floor temperature sensor or an external room temperature sensor can be used.

#### Dewpoint monitoring

Dewpoint monitoring is essential to prevent condensation on the chilled ceiling (cooling with fan disabled, parameter P52). It helps avoid associated damage to the building.

A dewpoint sensor with a potential-free contact is connected to multifunctional input X1 or X2 (P38/P40 = 4). If there is condensation, the cooling valve is fully closed until no more condensation is detected, and the cooling output is disabled temporarily.

If the fan function is enabled (P52 ≠ 0), the fan continues to work while the dewpoint function is active.

## 4.5.5 User operation / Indication

### Key lock (P14)

If the "Key lock" function is enabled by P14, lock or unlock all buttons by pressing the operating mode button for 5 seconds.

If "Auto lock" is configured, the thermostat automatically locks the buttons 10 seconds after the last adjustment; unlock the buttons as per manual locking.

P14 can be configured as following:

P14	
0	Unlocked
1	Lock (all lock)
2	Setpoint adjustable

## 4.5.6 Prevention operation

### Avoid damage from moisture (P61)

In very warm and humid climates, the fan runs periodically or continuously at a low fan speed (e.g., in empty apartments or shops) in Economy via setting P61, to avoid moisture damage due to lack of air circulation. See "Fan kick" function in Fan control [→ 37].

## 4.6 Control sequences

### 4.6.1 Overview of sequences (setting via P01)

The main control sequence (water coil sequence of the fan coil unit) can be set via P01.

The following sequences can be activated in the thermostats (with or without auxiliary heating).

The available sequences depend on the application (selected via DIP switches, see Application overview [→ 21]).

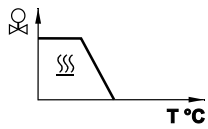
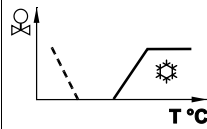
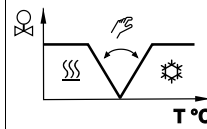
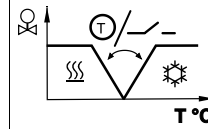
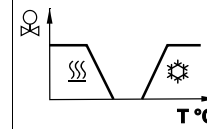
Parameter	P01 = 0	P01 = 1	P01 = 2	P01 = 3	P01 = 4
Sequence					
Available for basic application 1): ↓	Heating	Cooling - = heating sequence for electric heater/radiator	Manually select heating or cooling sequence (using HMI)	Automatic heating/cooling changeover via external water temperature sensor or remote switch	Heating and cooling sequence ,4-pipe
2-pipe 2-pipe with el. heater	✓	✓	✓	✓	-
4-pipe	-	-	✓ <sup>2)</sup>		✓

<sup>1)</sup> For chilled/heated ceiling and radiator applications, see Chilled/heated ceiling and radiator applications [→ 34];

for compressor applications, see Compressor applications [→ 34]

<sup>2)</sup> For manual changeover with 4-pipe applications, see 4-pipe fan coil unit [→ 33].

- 4-pipe manual changeover (P01 = 2) means activating either cooling or heating outputs

For the relationship between setpoints and sequences, see Setpoints and sequences [→ 35].

### 4.6.2 2-pipe fan coil unit

In 2-pipe applications, the thermostat controls a valve in heating/cooling mode with changeover (automatically or manually), heating only, or cooling only (factory setting, P01 = 1).

#### On/Off control

Control sequence  
On/Off output

The diagrams below show the control sequence for On/Off control.

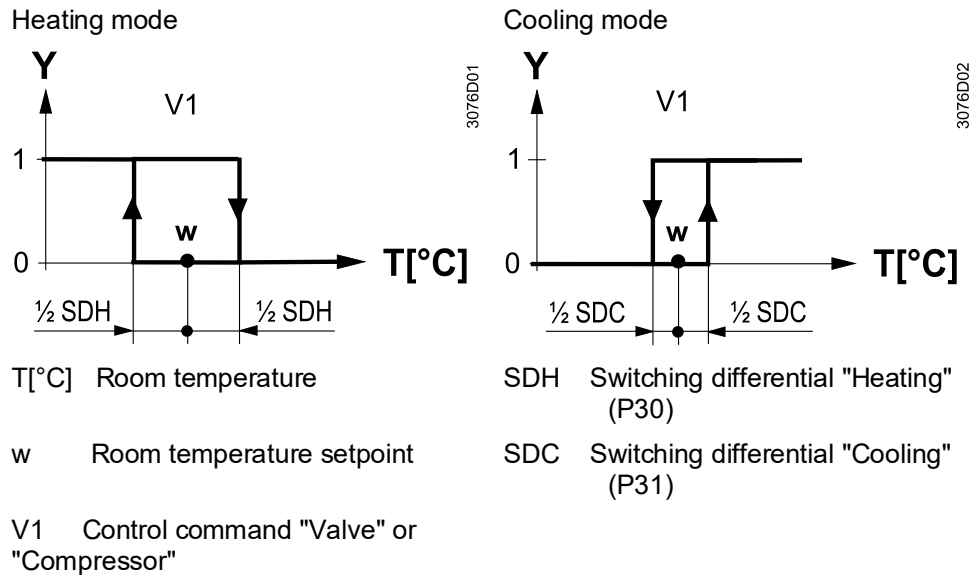

#### Modulating control: 3-position

Control sequence  
modulating output

The diagrams below show the control sequence for modulating PI control.

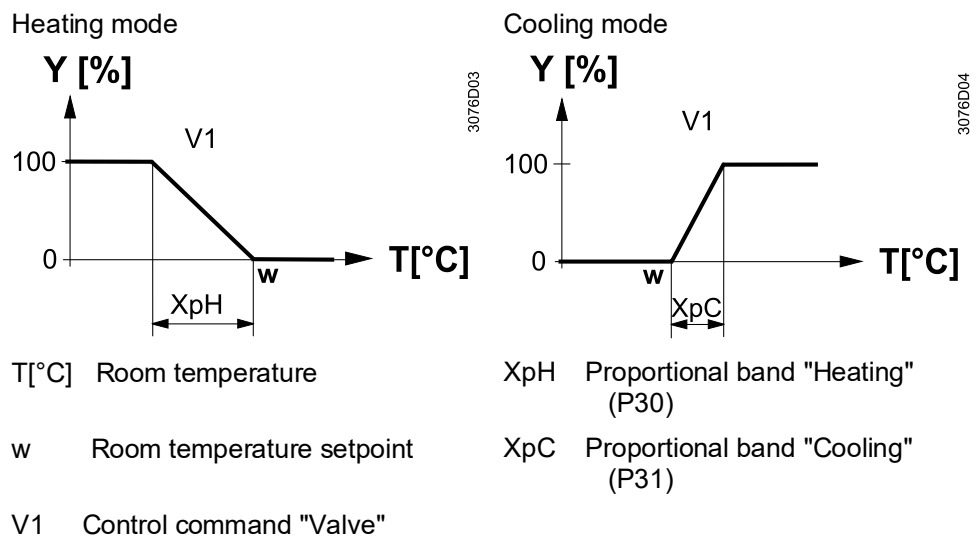

#### Note

The diagrams only show the PI thermostat's proportional part.  
To set sequence and control outputs, see Application overview [→ 21], Overview of sequences (setting via P01) [→ 30] and Control outputs [→ 36].

### 4.6.3 2-pipe fan coil unit with electric heater

#### Heating or cooling with auxiliary heater

In 2-pipe applications with electric heater, the thermostat controls a valve in heating/cooling mode with changeover, heating only, or cooling only plus an auxiliary electric heater.

Cooling only is factory-set (P01 = 1) with enabled electric heater (P13).

#### Electric heating, active in cooling mode

In cooling mode, the valve receives an **Open** command if the acquired temperature is above the setpoint.

The electric heater receives an **On** command if the acquired room temperature drops below "setpoint" minus "dead zone" (= setpoint for electric heater) while the electric heater is enabled (P13 = ON).

#### Note

"Setpoint for electric heater" is limited by parameter "Maximum setpoint for Comfort mode" (P10).

#### Electric heating in heating mode

In heating mode, the valve receives an **Open** command if the acquired temperature is below the setpoint. The electric heater is used as an additional heating source when the heating energy controlled by the valve is insufficient.

The electric heater receives an **On** command, if the temperature is below "setpoint" minus "setpoint differential" (= setpoint for electric heater).

#### Electric heating and manual changeover

The electric heater is active in heating mode only and the control output for the valve is permanently disabled when manual changeover is selected (P01 = 2).

#### Digital input "Enable electric heater"

Remote enabling/disabling of the electric heater is possible via input X1 or X2 for tariff regulations, energy savings, etc.

Input X1 or X2 must be commissioned accordingly (P38, P40). See Multifunctional input, digital input [→ 40].

#### On/Off control

Control sequence  
On/Off output

The diagrams below show the control sequence for On/Off control.

Heating mode  
(automatic changeover = heating or heating only)

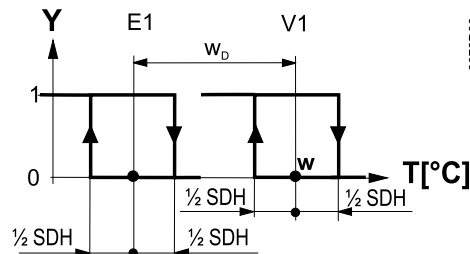

Cooling mode  
(man. / auto. changeover = cooling or cooling only)

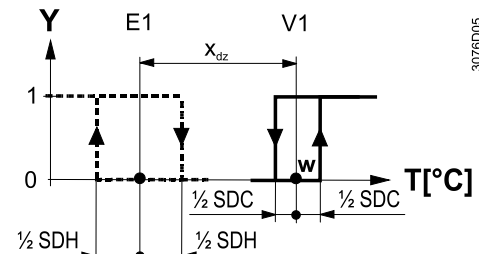

Heating mode with manual changeover (P01 = 2) (manual changeover = heating)

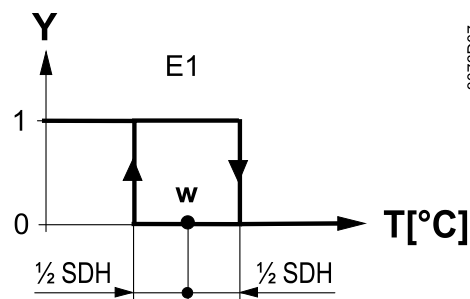

3076D07

T [°C] Room temperature  
W Room temperature setpoint  
V1 Control command "Valve" or "Compressor"  
E1 Control command "Electric heater"  
SDH Switching differential "Heating" (P30)  
SDC Switching differential "Cooling" (P31)  
Xdz Dead zone (P33)  
wD Setpoint differential (P34)

#### Note

- The diagrams only show the PI thermostat's proportional part.
- For setting sequence and control outputs, see Application overview [→ 21], Overview of sequences (setting via P01) [→ 30] and Control outputs [→ 36].



### 4.6.4 4-pipe fan coil unit

**Heating and cooling**

In 4-pipe applications, the thermostat controls 2 valves in heating and cooling mode, heating/cooling by manual selection, or heating and cooling mode with changeover. Heating and cooling (P01 = 4) is factory-set.

**4-pipe application with manual changeover**

The heating or cooling output can be released via operating mode button if P01 is set to Manual (P01 = 2).

**On/Off control**

The diagrams below show the control sequence for On/Off control.

Heating and cooling mode (P01 = 4)

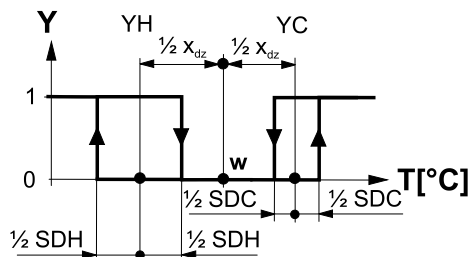

- T[°C] Room temperature
- w Room temperature setpoint
- YH Control command "Valve" (heating)
- YC Control command "Valve" (cooling)
- SDH Switching differential "Heating" (P30)
- SDC Switching differential "Cooling" (P31)
- X<sub>dz</sub> Dead zone (P33)

Heating mode with manual selection (P01 = 2) or for energy saving (P09 ≥ P10) in heating sequence

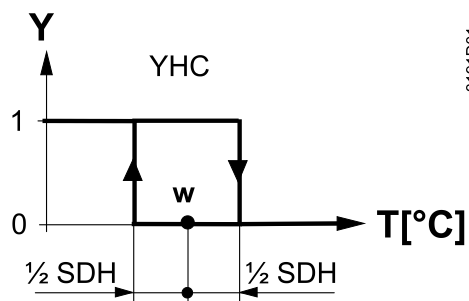

Cooling mode with manual selection (P01 = 2) or for energy saving (P09 ≥ P10) in cooling sequence

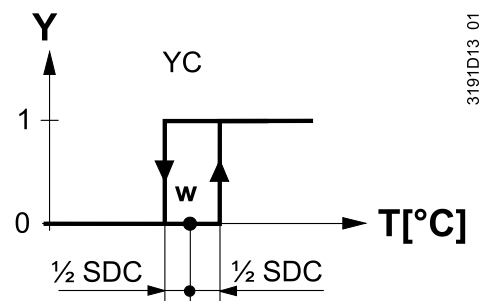

**Note**

The diagrams only show the PI thermostat's proportional part. For setting sequence and control outputs, see Application overview [→ 21], Overview of sequences (setting via P01) [→ 30] and Control outputs [→ 36].

### 4.6.5 Chilled/heated ceiling and radiator applications

For chilled/heated ceiling and radiator applications

- Set the corresponding basic application see Application overview [→ 21].
- Disable the fan (P52)

The following applications are available:

Application for chilled/heated ceiling, radiator	Set basic application	Section	Sequences
Chilled/heated ceiling with changeover	2-pipe	2-pipe fan coil unit [→ 31]	H ( \ ) C ( / )
Chilled/heated ceiling and electric heater (cooling only: disable electric heater via P13)	2-pipe with electric heater	2-pipe fan coil unit with electric heater [→ 32]	EI H + H ( ʒ \ ) EI H + C ( ʒ / ) C ( / ) EI H ( ʒ )
Chilled ceiling and radiator	4-pipe	4-pipe fan coil unit [→ 33]	H + C ( \ / )

### 4.6.6 Compressor applications

For compressor applications,

- Set the corresponding basic application
- Disable the fan (P52) or set the type of fan speed (P53)

The following applications are available:

Application for compressor	Set basic application	Section	Sequences
1-stage compressor for heating or cooling	2-pipe	2-pipe fan coil unit [→ 31]	H ( \ ) C ( / )
1-stage compressor and electric heater (for cooling only: disable electric heater via P13)	2-pipe with electric heater	2-pipe fan coil unit with electric heater [→ 32]	EI. H + H ( ʒ \ ) EI. H + C ( ʒ / ) C ( / )
1-stage compressor for heating and cooling	4-pipe	4-pipe fan coil unit [→ 33]	H + C ( \ / )

#### Note

Minimum On/Off time:	P48/P49
Fan operation:	P52 (0 = disabled, 1 = enabled)
Fan speed:	P53 (3 = DC 0...10 V (ECM fan))

### 4.6.7 Setpoints and sequences

#### 2-pipe applications

In changeover applications, the Comfort setpoints for the heating and cooling sequences are identical (w).

In 2-pipe applications with electric heater, the Comfort setpoint is either at the first heating sequence (in heating) or at the cooling sequence (in cooling).

The setpoints for Economy and Protection are below the Comfort setpoints (for heating) and above the Comfort setpoints (for cooling).

They can be set via P11, P12 (Economy) and P65, P66 (Protection).

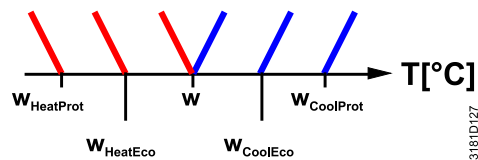

Application	Comfort		Economy/Protection	
	Heating	Cooling	Heating	Cooling
2-pipe				
2-pipe with electric heater				

1) If P13 = ON

2) If manual changeover is selected (P01 = 2), only electric heating is available.

W = Setpoint in Comfort

W<sub>HeatEco/Prot</sub> = Setpoint heating in Economy or Protection

W<sub>CoolEco/Prot</sub> = Setpoint cooling in Economy or Protection

YE = Electric heater sequence

#### 4-pipe applications

In 4-pipe applications, the Comfort setpoint (w) is in the middle of the dead zone, between the heating and cooling sequence.

The dead zone can be adjusted via P33.

If manual changeover is selected, then either the cooling sequence or the heating sequence is released. Here, the Comfort setpoint is at the selected heating or cooling sequence.

Application	Comfort			Economy/Protection
	Heating and cooling	Heating only <sup>1)</sup>	Cooling only <sup>1)</sup>	Heating and/or cooling
4-pipe				

1) Manual changeover, P01 = 2

W = Setpoint in Comfort

W<sub>HeatEco/Prot</sub> = Heating setpoint for Economy or Protection

W<sub>CoolEco/Prot</sub> = Cooling setpoint for Economy or Protection

## 4.7 Control outputs

### 4.7.1 Overview

#### Overview of control outputs

Different control output signals are available and defined during commissioning (see below).

Control output	2-position	3-position
<b>Product No.</b>		
RDF660T	Y1, Y2 (2 x SPST)	Y1, Y2 * (1 x ▼/▲)

\*) Only on 2-pipe application

#### On/Off control signal (2-position)

The valve receives the **Open/On** command via control output Y1 or Y2, if

1. The acquired room temperature is below the setpoint (for heating) or above the setpoint (for cooling).
2. The control outputs have been inactive for more than the "Minimum output off time" (factory setting 1 minute, adjustable via P48).

The valve receives the **Off** command, if

1. The acquired room temperature is above the setpoint (for heating mode) or below the setpoint (for cooling mode).
2. The valve has been active for more than the "Minimum output on time" (factory setting 1 minute, adjustable via P49).

#### Electric heater control signal (On/Off)

The electric heater receives an **On** command via the auxiliary heating control output (Y..., see Mounting Instructions [→ 5] [1]), if

1. The acquired room temperature is below the "Setpoint for electric heater".
2. The electric heater is switched off for at least 1 minute.

The **Off** command for the electric heater is output, if

1. The acquired room temperature is above the setpoint (electric heater).
2. The electric heater is switched on for at least 1 minute.

**⚠ CAUTION! Provide a safety limit thermostat (to prevent over-temperature) externally.**

#### Adaptive temperature compensation for electric heater

When an electric heater is connected directly to the On/Off Y2, the current causes the relay contact to heat up. This falsifies the reading of the internal temperature sensor. The thermostat compensates the temperature if the rated current/power of the electric heating is entered in parameter P45 (load current electric heater): factory setting: 0 A, setting range: 0.0...5.0 A.

#### 3-position control signal

Heating: Output Y1 provides the **Open** command, and Y2 the **Close** command to the 3-position actuator.

The factory setting for the actuator run-time is 150 seconds and can be adjusted via P44.

The parameter is visible only, if 3-position is selected via DIP switch 2.

#### Synchronization

1. After the thermostat is powered up, a close command for the actuator run time by + 150 % is issued to ensure that the actuator closes fully and synchronizes to the control algorithm.
2. When the thermostat calculates "fully close" or "fully open", the actuator run time is extended by + 150 % to ensure the correct actuator position is synchronized to the control algorithm.
3. After the actuator reaches the position calculated by the thermostat, a waiting time of 30 seconds is applied to stabilize the outputs.

## 4.8 Fan control

The fan is in automatic mode or runs at the selected speed in manual mode.

In automatic mode, the fan speed is based on the setpoint and the current room temperature. When the room temperature reaches the setpoint, the control valve closes and the fan switches off or remains at fan speed 1 (parameter P15, factory setting: 0 = disabled).

### Fan control with On/Off heating/cooling control

In applications with On/Off (2-position) control:

1. The switching point for low fan speed is synchronized to the heating / cooling output.
2. The maximum switching range of the fan ( $XpH_{Fan} / XpC_{Fan}$ ) is defined by the switching differential (SDH/SDC) via a look-up table.

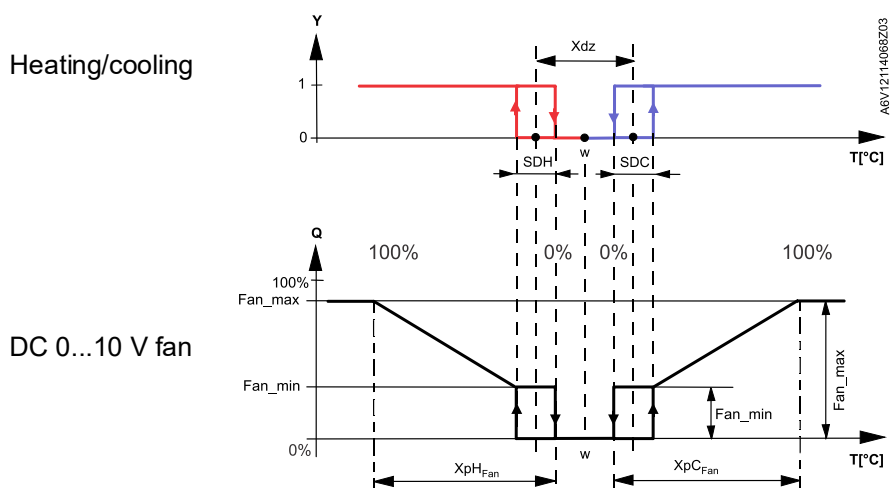

T [°C]	Room temperature	$X_{dz}$	Dead zone (P33)
w	Room temperature setpoint	$XpH_{Fan}$	Switching range for fan
Q	Fan speed	$XpC_{Fan}$	Switching range for fan
Y	Control command "Valve"		"Heating" (Table)
SDH	Switching differential "Heating" (P30)		Switching range "Cooling" (Table)
SDC	Switching differential "Cooling" (P31)		
		Fan_max	Max. DC 0...10 V fan speed (P55)
		Fan_min	Min. DC 0...10 V fan speed (P56)

### Look-up table with On/Off (2-position) control

SDH/SDC [K]	0.5	1.0	1.5	2.0	2.5	3.0	3.5	4.0	4.5	>4.5
$XpH_{Fan}/XpC_{Fan}$ [K]	2	3	4	5	6	7	8	9	10	

### Manual operation DC 0...10 V fan

Fan speed I = min. fan speed selectable via P56

Fan speed II = half-way between min. fan speed and max. fan speed

Fan speed III = max. fan speed selectable via P55

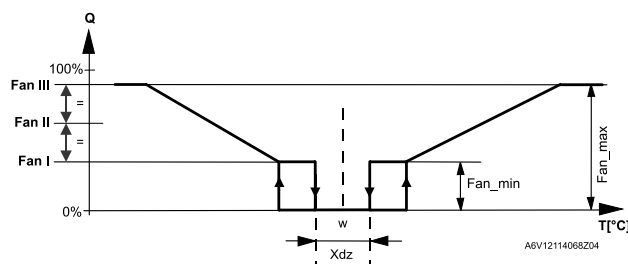

Note: Manual fan settings do not influence the control signals for "Heating" and "Cooling".

**Note**

When heating with the electric heater only, manual fan speed I is unavailable to ensure the required minimum air flow for the electric heater and to avoid overheating of the system.

**Fan operation as per heating/cooling mode, or disabled**

Fan operation can be limited to be active with cooling only or heating only, or even be totally disabled via control parameter "Fan control" P52.

When fan operation is disabled, the fan symbol on the display disappears and pressing the fan button has no impact.

This function allows users to use the thermostat in universal applications such as chilled/heated ceilings and radiator, etc. (see Chilled/heated ceiling and radiator applications [→ 34]).

**Fan minimum on- time**

In automatic mode, a dwelling time of 2 minutes (factory setting) is active. The fan maintains each speed for at least 2 minutes before it changes to the next speed. The minimum on-time can be adjusted from 1...6 minutes via parameter P59.

**Fan operation in dead zone (fan kick)**

In automatic fan mode and with the room temperature in the dead zone, the control valve is normally closed and the fan is disabled. With the fan kick function, the fan can be released periodically at low speed for a minimum on-time (see above) even if the valve is closed.

This function is used to avoid damage from moisture due to a lack of air circulation, or to allow the return air temperature sensor to acquire the correct room temperature.



① Periodic fan kick

② Minimum on-time

The periodic fan kick time can be selected individually for Comfort via parameter P60, and for Economy via parameter P61.

**Notes**

- Fan kick value 0 (OFF) means the fan does not run in the dead zone.
- Comfort:
  - Fan kick value 1...89 means the fan turns on at low speed every "x = 1...89" minutes and the duration is equal to the fan minimum on-time.
  - Fan kick value 90 means the fan runs continuously in the dead zone.
- Economy:
  - Fan kick value 1...359 means the fan turns on at low speed every "x = 1...359" minutes and the duration is equal to the fan minimum on-time.
  - Fan kick value 360 means the fan runs continuously in the dead zone.

**Fan start**

When the fan starts from a standstill, it starts at high speed for 1 second to ensure safe fan motor startup by overcoming inertia and friction (selected via parameter P67).

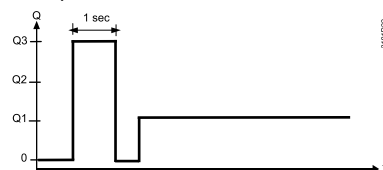
**Fan overrun for electric heater**

When the electric heater is switched off, the fan overruns for 60 seconds (parameter P54) to avoid overtemperature of the electric heater or prevent the thermal cutout from responding.



**⚠ WARNING**

**Fan failure**

In the event of fan failure, the thermostat cannot protect the electric heater against over-temperature. Thus, the electric heater must feature a separate safety device (thermal cutout).

- Clean fan filter reminder** The "Clean fan filter reminder" function counts the fan operating hours and displays message "FIL  " to remind users to change/clean the fan filter as soon as the threshold is reached. This does not impact the thermostat's operation, which continues to run normally. The function is set via parameter P62 (Service filter).
- Fault information** The "Clean filter reminder" is reset when the operating mode is manually set to Protection and back.
- Fan in Auto Timer mode** In Auto Timer mode, the default fan mode is automatic. The fan mode can be changed to Manual by pressing the FAN button. The fan returns to automatic mode after each switchover from Comfort to Economy, and vice versa.

## 4.9 Multifunctional input, digital input

The thermostat has 2 multifunctional inputs X1 and X2.

An NTC type sensor such as NTC 3k (AI, analog input) or a switch (DI, digital input) can be connected to the input terminals. The functionality of the inputs can be configured via P38 + P39 for X1, P40 + P41 for X2.

The parameters can be set to the following values:

#	Function of input	Description	Type X1/X2
0	Not used	No function	--
1	Room temperature external sensor/return air temperature	Sensor input for external room temperature sensor or return air temperature sensor to acquire the current room temperature, or floor heating temperature sensor to limit the heating output. <b>Note:</b> The room temperature is acquired via the built-in sensor if the floor temperature limitation function is enabled in parameter P51.	AI
2	Heating/cooling changeover	Analog input for "Automatic heating/cooling changeover" function. A sensor can be connected via input X1 or X2. (For heating/cooling changeover, see Sensors and changeover functions [→ 26].	AI
3	Window contact	Digital input to change over the operating mode to Protection. If the window contact is active, user operations are ineffective.	DI
4	Dewpoint sensor	Digital input for a dewpoint sensor to detect condensation. Cooling is stopped if condensation occurs.	DI
5	Enable electric heater	Digital input to enable/disable the electric heater via remote control.	DI
6	Fault input	Digital input to signal an external fault (e.g.: dirty air filter). <b>Note:</b> Fault displays have no impact on the thermostat's operation. They merely represent a visual signal.	DI
7	Monitor input (digital)	Digital input to monitor the state of an external switch	DI
8	Monitor input (analog)	Sensor input to monitor the state of an external sensor (e.g., NTC 3k)	AI
9	Heating/cooling changeover	Digital input for "Automatic heating/cooling changeover" function. A switch instead of a sensor can also be connected. (Switch closed = cooling, see Additional functions [→ 25]) Diagnostic value <b>0 °C</b> is displayed for a closed contact, <b>100 °C</b> for an open contact, if a switch is connected.	DI



#	Function of input	Description	Type X1/X2
10	Presence detector	The presence detector input switches the operating mode to Comfort when the room is occupied and returns to the previous operating mode when the room is unoccupied. See also Hotel keycard/Presence detector [→ 27]	DI
11	Hotel keycard	The hotel keycard input switches the operating mode to Economy with HMI locked when the room is unoccupied and returns to the previous operating mode when the room is occupied. See also Hotel keycard/Presence detector [→ 27]	DI

- The control action can be changed from normally open (NO) and normally closed (NC) via parameter P39, P41.
- Each input X1 or X2 must be configured with a different function (i.e. 1...5 & 9...11). Exception: X1 or X2 input can be configured with same function (i.e. 6, 7, 8).
- X1 is factory-set to "Window contact" (3), X2 to "Room temperature external sensor/return air temperature" (1).

If a multifunctional input is configured as analog: "Er3" is displayed when the output is out of range (0...49 °C), open or shorted.

For detailed information, see Application overview [→ 21].

**Note**

- For inputs X1 and X2, one physical switch can be used for up to 20 thermostats (parallel connection).

Caution! Do not mix X1 and X2.

- For sensors on inputs X1 or X2, the maximum cable length is 80 m.

## 4.10 Auto Timer

The thermostat provides an Auto Timer mode with 8 programmable timers. Each timer can be assigned to one or several days. In this mode, the thermostat automatically changes over between Comfort and Economy as per the preprogrammed timers.

Auto Timer for Comfort

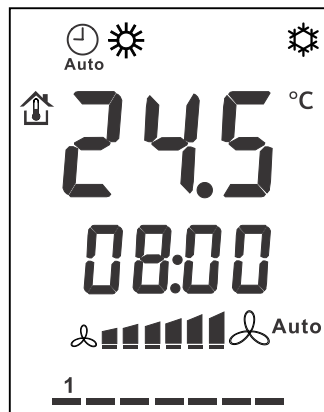

Auto Timer for Economy



### Set timers



Each timer has a Comfort start and end time that can be applied to one or several weekdays.

To adjust the time schedule, press the  button for 3 seconds to enter the programmable timer setting mode.

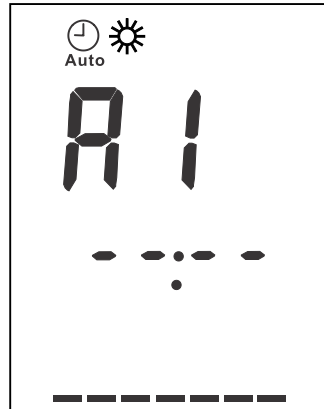

This mode is indicated by Ax (x= auto timer 1...8) and the time -- : -- flashes.





Proceed as follows for each Auto Timer:

1. The  and  symbols are displayed. Press + or - button to adjust the Comfort start time and confirm by pressing .



2. The  and  symbols are displayed. Press + or - button to adjust the Comfort end time or Economy start time and confirm by pressing .



3. Symbol  flashes. Press + or - button to select or clear each day and go to the next day. Confirm the actual timer settings by pressing  and go to the next timer.



The thermostat closes the programmable timer setting mode if there is no operation within 20 seconds. All changes made after pressing the button for the last time are lost.

### View timers

Press the button  to view the 8 timers in sequence.

### Default timer setting



Timers A1...A4 have the following default settings (residential use):

Day	Timer when thermostat is in Comfort mode	
Mo (1) – Fr (5)	06:30 – 08:30 (A1)	17:30 – 22:30 (A2)
Sa (6)	08:00 – 23:00 (A3)	
Su (7)	08:00 – 22:30 (A4)	
	<ul style="list-style-type: none"> <li>For the remainder, the controller is in Economy .</li> <li>Timers A5...A8 are open, no default setting.</li> </ul>	

### Reload default timer setting

The setting of timers can be changed to individual needs.

The default setting can be reloaded any time:

- Set the controller to Protection .
- Press and hold + and - buttons or 3 seconds. Release and press  twice within 2 seconds.

Then, the display shows “8888” while reloading.

### Overlapping of timer sequences

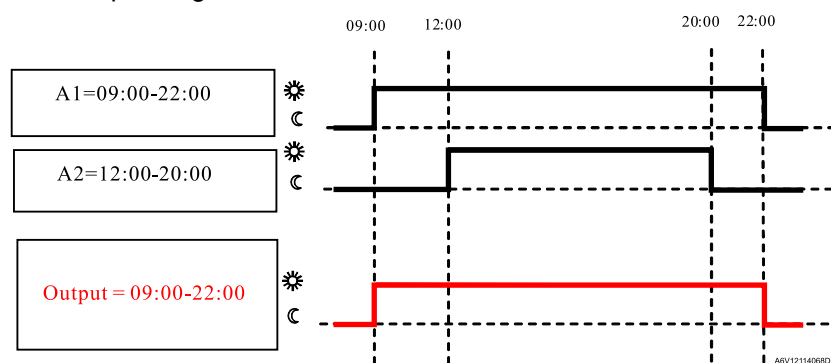

When several timer sequences overlap, the output is the OR combination of the normal operating mode time of all timers.



### 7-day time clock

The 7-day time clock supports 12-hour and 24-hour format. Select the format while setting the time clock as follows:

#### Set the time clock

- Keep pressing the  button until the time digits flash and then press + or - button to set the time of day. If the current time is in 24-hour format and you want to change to 12-hour format, press + button passing 23:59 or press - button passing 00:00 and vice versa to return to 24-hour format.
- Confirm the time of day by pressing  and the weekday indicator flashes.
- Press + or - button to set the current weekday.
- Confirm the current weekday by pressing .

### Power failure

In the event of a power failure, the clock stops, but its last time is stored. The time information is reloaded and starts running after power on. The clock flashes to indicate that there was a power failure until the time is confirmed by pressing , or readjusted following above steps 1 to 4.

## 4.11 Handling system faults

### Temperature out of range

If the room temperature exceeds or drops below the measuring range, i.e. above 49 °C or below 0 °C, the limiting temperatures blink, e.g., **0 °C** or **49 °C**.

In addition, the heating output is activated if the current setpoint is not set to Off, the thermostat is in heating mode and the temperature is below 0 °C.

For all other cases, no output is activated.

The thermostat resumes Comfort mode as soon as the temperature is within the measuring range.

### Power failure

In the event of a power failure, all working conditions (operating mode, setpoint, fan stage, all control parameter settings) are stored without time limitation. When power returns, user and parameter settings can be retained with power loss and operating mode can be returned to previous operating mode, Comfort or Protection (depends on P27).

For thermostat with Auto Timer, see Auto Timer [→ 42].

## 4.12 Infrared remote control

Use IRA211 infrared remote control to operate a controller with built-in infrared receiver. The following operations can be done remotely:

- Select operating modes Protection, Comfort or Auto Timer
- Adjust setpoint in Comfort
- Select fan modes automatic or manual

A buzzer in the thermostat indicates remote control command reception.

Infrared remote control can be disabled via P70.

## 4.13 Control parameters

To optimize control performance, a number of control parameters can be readjusted on the thermostat via HMI.

In the event of a power failure, all control parameter settings are retained.

The control parameters are assigned to 2 levels:

- Service level, and
- Expert level, including communications, diagnostics and test

The Service level contains a small set of parameters to set up the thermostat for the HVAC system and to adjust the user interface. These parameters can be adjusted any time.

The parameters at the Expert level need careful configuration because they impact the thermostat's control performance and functionality.

### 4.13.1 Parameter setting via local HMI

#### Enter only Service level

1. Press + and - buttons simultaneously for more than 6 seconds. Release and within 2 seconds, press + button again for more than 3 seconds until **P01** is displayed. Continue with step 2.

#### Enter Expert level with Diagnostics and test

1. Press + and - buttons simultaneously for more than 6 seconds. Release and within 2 seconds, press - button again for more than 3 seconds until **P01** and service are displayed. Continue with step 2.

2. Repeatedly press the + or - button to select the required parameter.

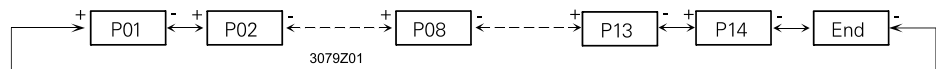

3. Press + and – simultaneously once to enter EDIT mode. Then press + or – button to change the value of the selected parameter and press + and – simultaneously to save the change.
4. Repeat steps 2 to 3 to display and change additional parameters.
5. Press + or – until “End” is displayed, and then press + and – simultaneously to exit parameter entry mode.

#### Reset parameters

The factory setting for the control parameters can be reloaded via P71, by changing the value to On. Confirm the change by pressing + and - buttons simultaneously.

**8888** is displayed during reload and the device restarts 4 s later.

### 4.13.2 Service level parameters

Parameter	Name	Factory setting	Range
	Service level		
P01	Control sequence if 2-pipe applications are selected	1	0 = Heating only 1 = Cooling only 2 = H/C changeover manual 3 = H/C changeover auto
	Control sequence if 4-pipe application is selected	4	2 = H/C changeover manual 4 = Heating and cooling
P02	Mode selection via room operating mode button	1	1 = Auto - Comfort – Protection 2 = Auto - Comfort – Economy – Protection 3 = Comfort – Protection 4 = Comfort – Economy – Protection
P04	Unit	0	0 = °C (Celsius) 1 = °F (Fahrenheit)
P05	Measure value correction (for built-in/external sensor)	0	- 5...5 K
P06	Standard display	0	0 = Room temperature 1 = Setpoint
P07	Additional display information	0	0 = No display 1 = Room temp °C or °F 2 = Setpoint 3 = Time of day (12-hour) 4 = Time of day (24-hour)
P08	Comfort basic setpoint	21 °C	5...40 °C
P09	Minimum Comfort setpoint	5 °C	5...40 °C
P10	Maximum Comfort setpoint	35 °C	5...40 °C
P11	Economy heating setpoint	5 °C	Off 5...WCoolEco (P12) WCoolEco (P12) = 40 °C max.
P12	Economy cooling setpoint	30 °C	Off WHeatEco (P11)...40 °C WHeatEco (P11) = 5 °C min.
P13 <sup>1)</sup>	Electric heater when cooling	1	0 = Disabled 1 = Enabled
P14	Key lock	0	0 = Unlock 1 = Lock (all lock) 2 = Setpoint adjustable
P15	Fans stage in dead zone (Comfort)	0	0 = Disabled 1 = Low speed (heating and cooling) 2 = Low speed (cooling only)
P27	Operating mode after power failure	0	0 = Previous operating mode 1 = Off mode (Protection) 2 = On mode (Comfort)

<sup>1)</sup> Only available when application is 2-pipe with electric heater

### 4.13.3 Expert level parameters with diagnostics and test

Parameter	Name	Factory setting	Range
	Service level		
P30	Heat P-band Xp/switching differential	2 K	0.5...6 K
P31	Cool P-band Xp/switching differential	1 K	0.5...6 K
P32	Integral time (fan)	0 min	0 ...20 min
P33	Dead zone Comfort mode	2 K	0.5...5 K
P34	Setpoint differential	2 K	0.5...5 K
P35	Integral action time Tn	45 min	0...120 min
P36	H/C changeover switching point cooling	16 °C	10...25 °C
P37	H/C changeover switching point heating	28 °C	27...40 °C
P38	Input X1	3	0 = --- (no function) 1 = Room temp ext. sensor/ return air temp (AI) 2 = H/C changeover (AI) 3 = Window contact (DI) 4 = Dew point sensor (DI) 5 = Enable electric heater (DI) 6 = Fault input (DI) 7 = Monitor input (DI) 8 = Monitor input (AI) 9 = H/C changeover (DI) 10 = Presence detector (DI) 11 = Hotel keycard (DI)
P39	Normal position input X1	0	0 = Normally open/open 1 = Normally closed/close
P40	Input X2	1	0 = --- (no function) 1 = Room temp ext. sensor/ return air temp (AI) 2 = H/C changeover (AI) 3 = Window contact (DI) 4 = Dew point sensor (DI) 5 = Enable electric heater (DI) 6 = Fault input (DI) 7 = Monitor input (DI) 8 = Monitor input (AI) 9 = H/C changeover (DI) 10 = Presence detector (DI) 11 = Hotel keycard (DI)
P41	Normal position input X2	0	0 = Normally open/open 1 = Normally closed/close
P44	Actuator running time Y1/Y2	150 s	20...300 s
P45	Power of electric heater on Y2 (for adaptive temperature compensation)	0	0.0...1.2 kW resolution 0.1 Kw
P48	2-pos output minimum ON time	1 min	1...20 min
P49	2-pos output minimum OFF time	1 min	1...20 min
P50	Purge time	0	0 = Inactive or 1...5 minutes
P51	Floor heating temperature limitation	0	0 = Off or 10...50 °C
P52	Fan control	1	0 = Disabled 1 = Enabled 2 = Heating only



Parameter	Name	Factory setting	Range
	Service level		
			3 = Cooling only
P54	Fan overrun time	60 s	0...360 s
P55	ECM fan max. output	80 %	ECM fan min...100 %
P56	ECM fan min. output	30 %	1%... ECM fan max.
P59	Fan minimum ON time	2 min	1...6 min
P60	Periodic fan kick Comfort	0	0 = Off or 1...89 minutes 90 = Fan continues to run
P61	Periodic fan kick Eco	0	0 = Off or 1...359 minutes 360 = Fan continues to run
P62	Fan filter service reminder	0	0 = Off or 100...9900 h
P65	Protection heating setpoint	8 °C	0 = Off 5...WCoolProt (P66) WCoolProt (P66)= 40 °C max.
P66	Protection cooling setpoint	0	0 = Off WHeatProt (P65)...40 WHeatProt (P65) = 5 °C min.
P67	Fan start delay	0	0 = Off or 1...360 s
P68	Extension Comfort mode	0	0 = Off or 1...360 min
P69	Temporary Comfort setpoint	0	0 = Disable 1 = Enable
P70	Infrared receiver	1	0 = Disable 1 = Enable
P71	Restore factory setting	0	0 = Disable 1 = Reload start
P77	Time scheduler function	1	0 = Disable 1 = Enable

## Diagnostics and test

Parameter	Name	Factory setting	Range
	Service level		
d01	Application number	-	NONE = (No application) 2P = 2-pipe 2P3P = 2-pipe 3-position 2PEH = 2-pipe with electric heater 4P = 4-pipe
d02	X1 status	-	"---" = Function not selected 0 = Not activated (for DI) 1 = Activated (DI) 0...49 = Current temp. value (for AI) -100 == Out-of-service (for AI) 00 = H/C Input shorted 100 = H/C Input open
d03	X2 status	-	"---" = Function not selected 0 = Not activated (for DI) 1 = Activated (DI) 0...49 = Current temp. value (for AI) -100 == Out-of-service (for AI) 00 = H/C Input shorted 100 = H/C Input open
d05	Test mode for checking the Y1/Y2 actuator's running direction	-	0 = Output controlled by application 1 = 2-pipe on/off valve forced opening 2 = 2-pipe on/off valve forced closing 3 = 2-pipe 3-pos valve forced opening 4 = 2-pipe 3-pos valve forced closing 5 = 4-pipe heating valve forced opening 6 = 4-pipe heating valve forced closing 7 = 4-pipe cooling valve forced opening 8 = 4-pipe cooling valve forced closing 9 = Electrical heating valve forced opening 10 = Electrical heating valve forced closing
d06	Test mode for fan	-	0 = Output controlled by application 1 = Fan forced running 2 = Fan forced stop
d07	Software version	-	x.x.xx is displayed

## 5 Connection

### 5.1 Connection terminals

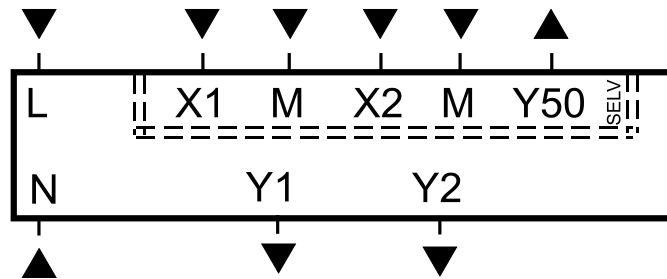

L, N Operating voltage AC 230 V

Y50 DC 0...10 V fan output

M Reference for DC fan

Y1, Y2 Control output "Valve" AC 230 V (N.O., for normally closed valves), output for compressor or output for electrical heater

X1, X2 Multifunctional input for temperature sensor (e.g. QAH11.1) or potential-free switch

M Measuring neutral for sensor and switch

### 5.2 Connection diagrams

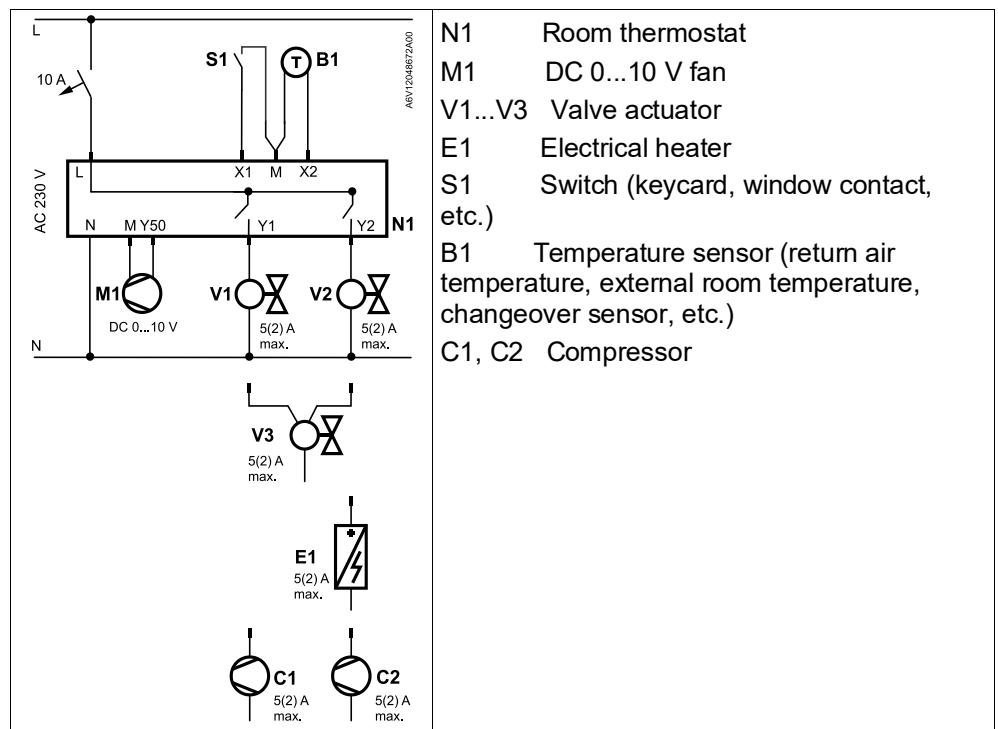

## 6 Technical data

Power supply	
Operating voltage	AC 230 V
Frequency	50/60 Hz
Power consumption	9 VA
External supply line protection (EU)	Circuit breaker max. 10 A characteristic B, C, D as per EN 60898 or power source with current limitation of max. 10 A
 <ul style="list-style-type: none"> <li>• <b>No internal fuse!</b></li> </ul> External preliminary protection with max. C 10 A circuit breaker in the supply line required under all circumstances.	

Outputs	
DC fan control DC 0...10 V; Y50	SELV DC 0...10 V, max. 5 mA
Control output Y1-N / Y2-N (N.O.) Rating	AC 230 V Max. 5(2) A

Multifunctional inputs	
X1-M/X2-M	
Temperature sensor input	
Type	NTC (3 k $\Omega$ at 25 °C)
Temperature range	0...49 °C
Cable length	Max. 80 m
Digital input	
Operating action	Selectable (NO/NC)
Contact sensing	SELV DC 0...3.3 V, max. 1 mA
Parallel connection of several thermostats for one switch	Max. 20 thermostats per switch
Insulation against mains voltage (SELV)	III (4 kV), reinforced insulation

Function input	
External temperature sensor, heating/cooling changeover sensor, window contact, dewpoint sensor, enable electrical heater contact, alarm contact, presence detector, hotel keycard	Selectable X1: P38 X2: P40

Operational data		
Switching differential, adjustable		
Heating	(P30)	2 K (0.5...6 K)
Cooling	(P31)	1 K (0.5...6 K)
Setpoint setting and range		
Comfort	(P08)	21 °C (5...40 °C)
Economy	(P11-P12)	15 °C/30 °C (OFF, 5...40 °C)
Protection	(P65-P66)	8 °C/OFF (OFF, 5...40 °C)
Multifunctional inputs X1/X2		Selectable (0...11)
Input X1		3 (P38) Window contact (DI)
Input X2		1 (P40) External temperature sensor
Built-in room temperature sensor		
Measuring range		0...49 °C
Accuracy at 25 °C		< ±0.5 K
Temperature calibration range		±5 K
Settings and display resolution		
Setpoints		0.5 °C
Current temperature value displayed		0.5 °C

Environmental conditions	
Storage	IEC 60721-3-1
Climatic conditions	Class 1K3
Transport	IEC 60721-3-2
Climatic conditions	Class 2K3
Operation	IEC 60721-3-3
Climatic conditions	Class 3K5 <sup>1)</sup>

Standards and directives	
EU conformity (CE)	A5W00156993A*
RCM conformity	A5W00156996A*
Protective class	II as per EN 60730-1
Pollution class	Class 2
Degree of protection of housing	IP30 as per EN 60529
Housing flammability class according to UL94	V-0
Environmental compatibility	The product environmental declaration (A5W00139322A*) contains data on environmentally compatible product design and assessments (RoHS compliance, materials composition, packaging, environmental benefit, disposal).

General	
Connection terminals	Solid wires or prepared stranded wires 1 x 0.4... 1.5 mm <sup>2</sup>
Housing front color	RAL 9003 white
Weight without/with packaging	147.6 g/255.4 g

\*) The documents can be downloaded from <http://siemens.com/bt/download>.

1) No condensation is allowed.

## 7 Dimensions

Dimensions in mm

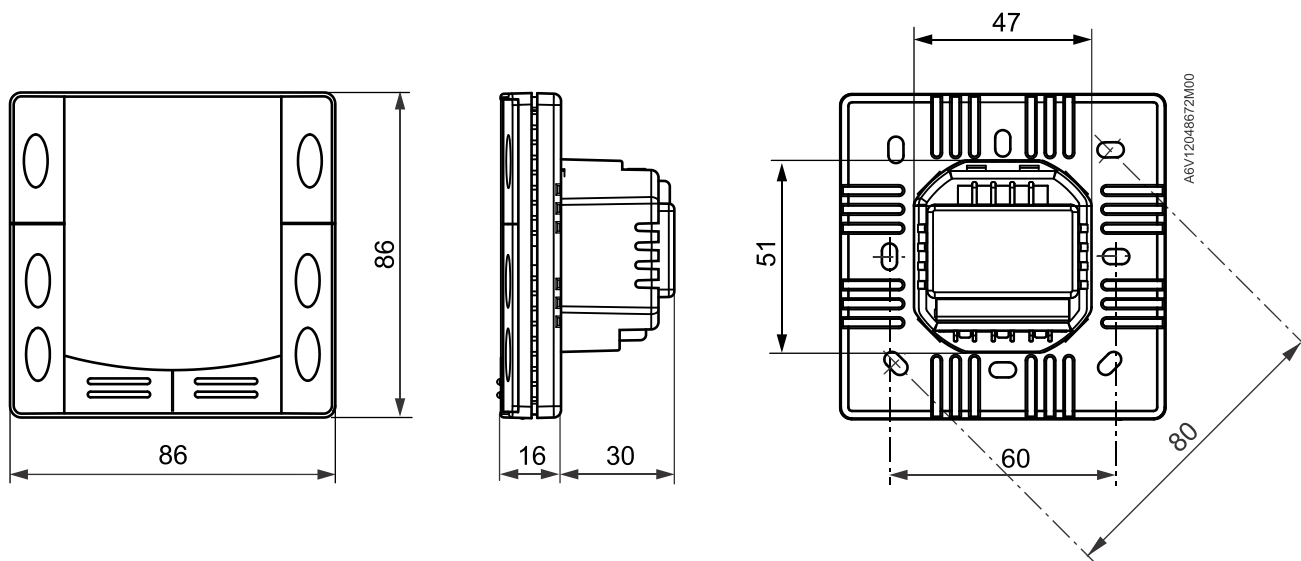

Dimensions in mm

# Index

- 1**  
12-hour and 24-hour format ..... 44
- 3**  
3-position control signal..... 36
- A**  
Auto Timer ..... 42  
Automatic heating/cooling changeover.....26, 30
- B**  
Basic application ..... 34
- C**  
Changeover switch..... 26  
Chilled/heated ceiling applications ..... 34  
Clean fan filter reminder ..... 39  
Commissioning..... 45  
Compressor application ..... 34  
Control outputs overview ..... 36  
Control parameters..... 45  
Control sequences..... 30  
Cooling sequence ..... 30
- D**  
Dewpoint monitoring ..... 28  
Dewpoint sensor..... 40
- E**  
Electric heater enable/disable ..... 40  
Enable/disable electric heater .....32, 40  
Expert level parameters..... 46  
External/return air temperature sensor..... 26
- F**  
Fan in Auto mode ..... 39  
Fan kick function ..... 38  
Fan minimum on- time ..... 38  
Fan operation as per heating/cooling mode, or disabled..... 38  
Fan operation in dead zone ..... 38  
Fan overrun..... 38  
Fan start ..... 38  
Fault handling ..... 45  
Fault input..... 40  
Floor cooling..... 27  
Floor heating..... 27  
Floor temperature limitation function ..... 28
- H**  
Heating and cooling sequence..... 30  
Heating sequence ..... 30
- Heating/cooling changeover .....26, 40
- I**  
Integral action time.....15
- K**  
Key lock .....29
- M**  
Manual heating/cooling changeover.....26  
Manually select heating or cooling sequence...30  
Minimum output.....27  
Moisture .....29  
Multifunctional input.....40
- O**  
On/Off control signal .....36  
Operating mode  
    Priority intervention .....17  
Operating mode button .....18
- P**  
Presence detector.....18  
programmable timers .....42  
Proportional band.....15  
Purge function .....27
- R**  
Radiator applications .....34  
Reload default timer setting.....44  
Remote heating/cooling changeover .....26  
Reset parameters.....46  
Room temperature external sensor/return air temperature.....40
- S**  
Set the time clock .....44  
Set timers .....42  
Setpoint Comfort .....35  
Setpoint Economy .....35  
Setpoint limitation .....19  
Setpoint Protection.....35  
Setpoints and sequences .....35  
Switching differential.....15  
Synchronization.....36
- T**  
Temperature out of range.....45  
Temporary setpoint .....19
- V**  
View timers .....43





---

**W**

Window contact .....18, 40

Issued by  
Siemens Switzerland Ltd  
Smart Infrastructure  
Global Headquarters  
Theilerstrasse 1a  
CH-6300 Zug  
+41 58 724 2424  
[www.siemens.com/buildingtechnologies](http://www.siemens.com/buildingtechnologies)

© Siemens Switzerland Ltd, 2021  
Technical specifications and availability subject to change without notice.

---

A6V12166490\_en--\_c